

INDICE	DATE	LIBELLE	AUTEUR
Matière:	Date 09/04/2024	Masse:	
Traitement:	Dessiné par:		
Tolérance générale: Js11	Indice:	Echelle:	Feuille N°
		BORNE AMOVIBLE	
		HQ-001	

Mouvements PHENIX

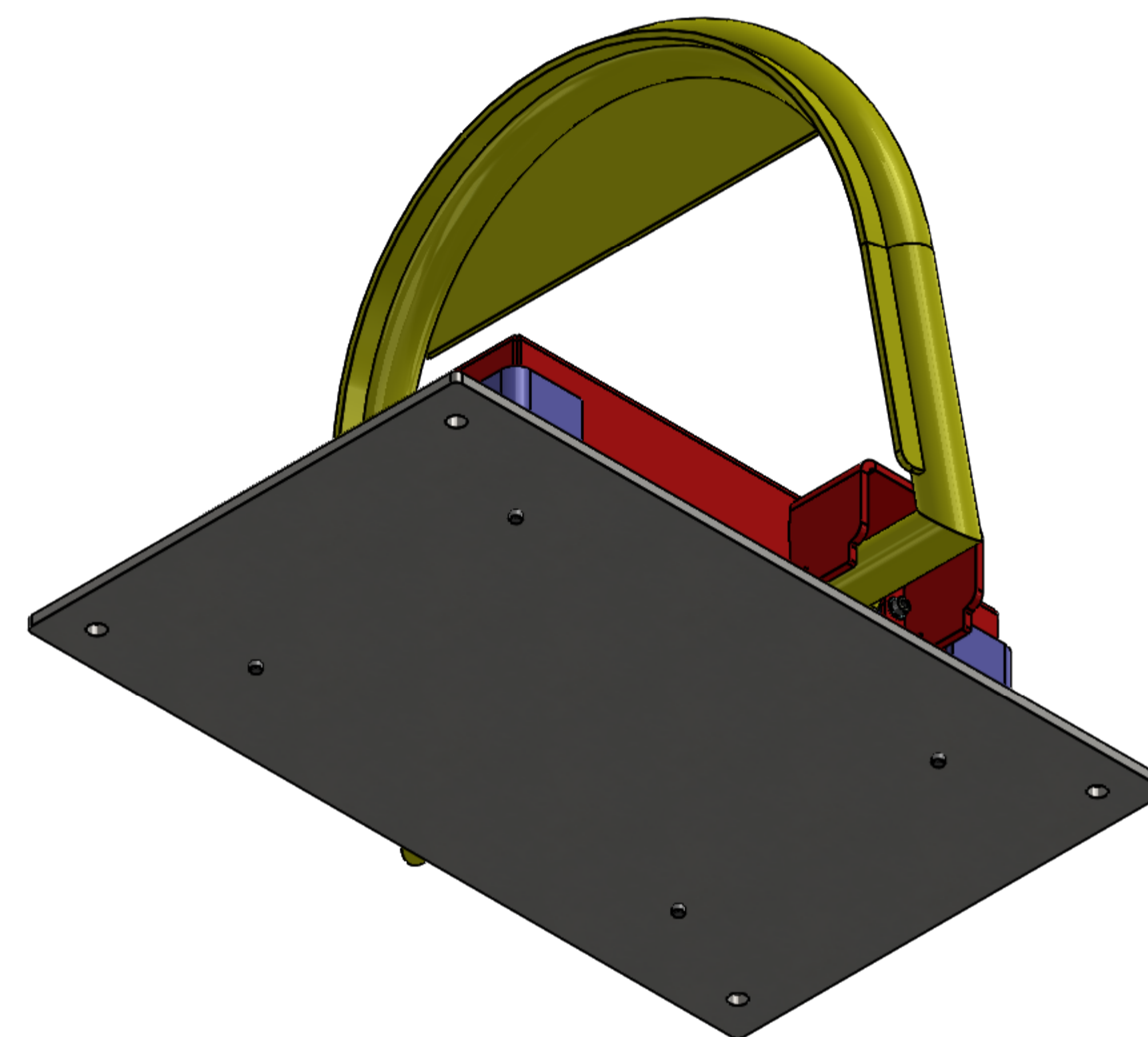
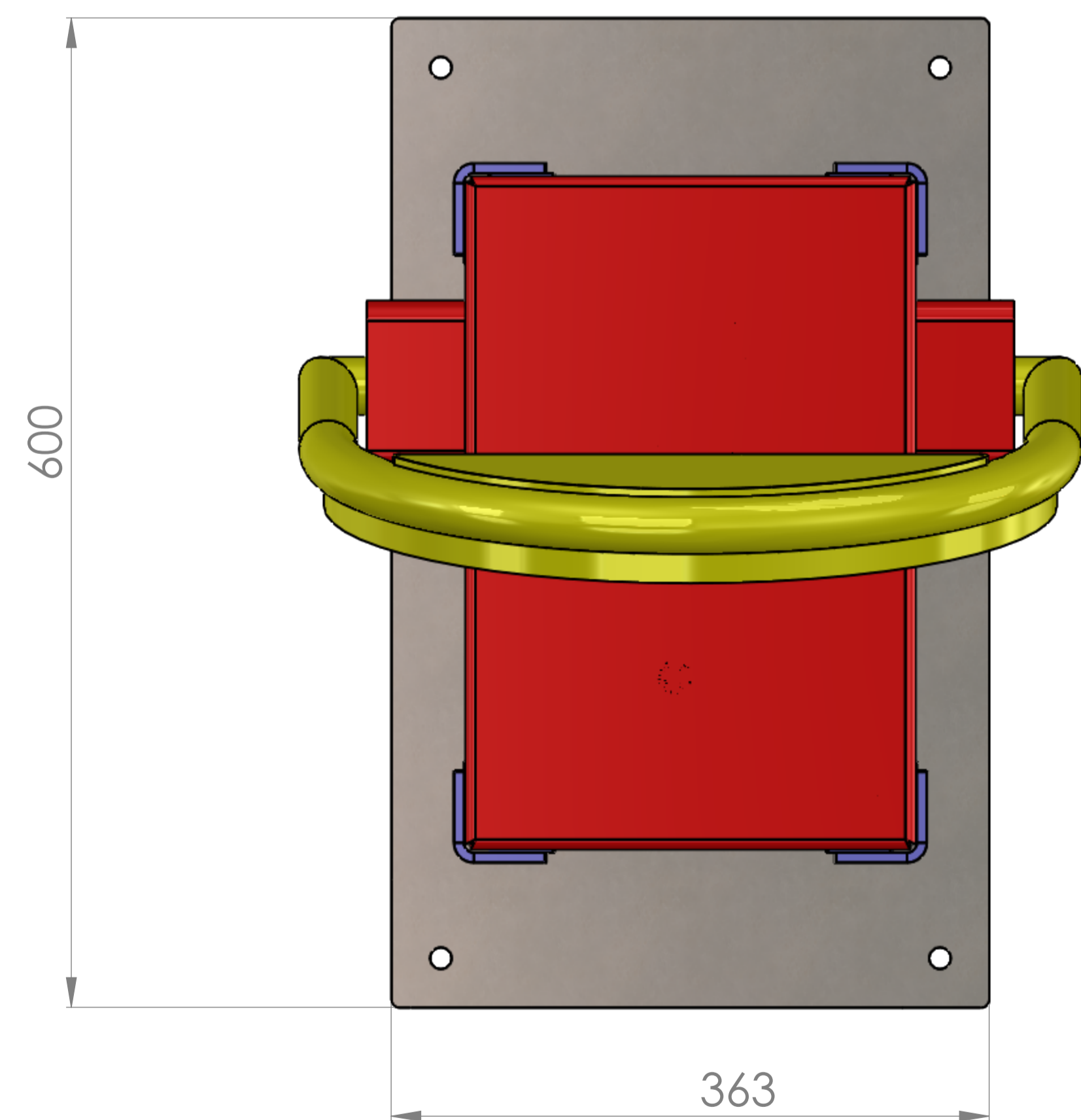
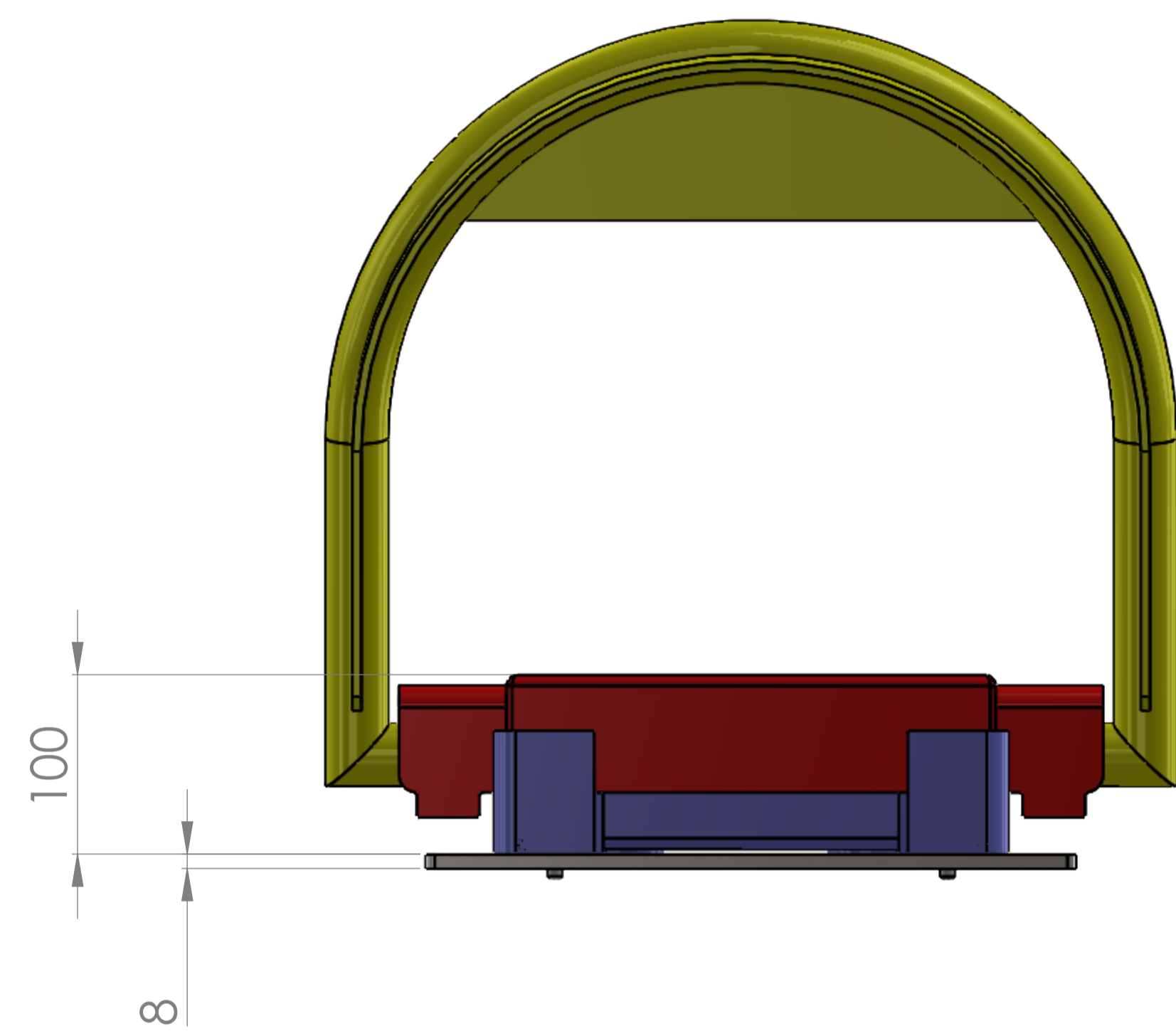

INDICE	DATE	LIBELLE	AUTEUR
Matière:		Date 09/04/2024	Masse:
Traitement:		Dessiné par:	
Tolérance générale: Js11	Indice:	Echelle:	Feuille N°
Mouvements PHENIX		BORNE AMOVIBLE	
		HQ-001	